

ALCEO
VOLCANO
Aluminum Hinged System
TV400

INDEX

NUMERIQUE

■P... 2-5	Certificates.
■P... 6-7	Technical Specification.
■P... 8-11	Techno form Data sheet
■P... 12-17	Beam Statics
■P... 18-19	Profiles List
■P... 20	Accessories
■P... 21-24	Profiles
■P... 25-26	Cutting List
■P... 27-35	Sections
■P... 36	3D Drawings



CERTIFICATE OF REGISTRATION

This is to certify that the management system of:
Al Dawlia 21 for Producing Coloring Aluminium Profiles
 Main Site: Third Industrial Zone – Piece 576 - 6th October City – Egypt
 has been registered by Intertek as conforming to the requirements of:
ISO 14001:2015

The management system is applicable to:
 Treatment, coating and wholesale of aluminum profiles.

Certificate Number:
 DBY060747-EMS-01
 Initial Certification Date:
 01 December 2010
 Date of Certification Decision:
 10 March 2018
 Issuing Date:
 10 March 2018
 Valid Until:
 30 November 2019



Calin Moldovean

Calin Moldovean
 President, Business Assurance
 Intertek Certification Limited, 10A Victory
 Park, Victory Road, Derby DE24 8ZF, United
 Kingdom
 Intertek Certification Limited is a
 UKAS accredited body under
 schedule of accreditation no. 014.



In the issuance of this certificate, Intertek assumes no liability to any party other than to the Client, and then only in accordance with the agreed upon Certification Agreement. This certificate's validity is subject to the organization maintaining their system in accordance with Intertek's requirements for systems certification. Validity may be confirmed via email at certification.validation@intertek.com or by scanning the code to the right with a smartphone. The certificate remains the property of Intertek, to whom it must be returned upon request.



CERTIFICATE OF REGISTRATION

This is to certify that the management system of:
Al Dawlia 21 for Producing Coloring Aluminium Profiles
 Main Site: Third Industrial Zone – Piece 576 - 6th October City – Egypt
 has been registered by Intertek as conforming to the requirements of:
ISO 9001:2015

The management system is applicable to:
 Treatment, coating and wholesale of aluminum profiles.

Certificate Number:
 DBY060747-QMS-01
 Initial Certification Date:
 01 December 2010
 Date of Certification Decision:
 10 March 2018
 Issuing Date:
 10 March 2018
 Valid Until:
 30 November 2019



Calin Moldovean

Calin Moldovean
 President, Business Assurance
 Intertek Certification Limited, 10A Victory
 Park, Victory Road, Derby DE24 8ZF, United
 Kingdom
 Intertek Certification Limited is a
 UKAS accredited body under
 schedule of accreditation no. 014.



In the issuance of this certificate, Intertek assumes no liability to any party other than to the Client, and then only in accordance with the agreed upon Certification Agreement. This certificate's validity is subject to the organization maintaining their system in accordance with Intertek's requirements for systems certification. Validity may be confirmed via email at certification.validation@intertek.com or by scanning the code to the right with a smartphone. The certificate remains the property of Intertek, to whom it must be returned upon request.



CERTIFICATE OF REGISTRATION

This is to certify that the management system of:
Al Dawlia 21 for Producing Coloring Aluminium Profiles
 Main Site: Third Industrial Zone – Piece 576 - 6th October City – Egypt
 has been registered by Intertek as conforming to the requirements of:
OHSAS 18001:2007

The management system is applicable to:
 Treatment, coating and wholesale of aluminum profiles.

Certificate Number:
 DBY060747-OHSAS-01
 Initial Certification Date:
 01 December 2010
 Date of Certification Decision:
 01 November 2016
 Issuing Date:
 02 November 2016
 Valid Until:
 30 November 2019



Calin Moldovean

Calin Moldovean
 President, Business Assurance
 Intertek Certification Limited, 10A Victory
 Park, Victory Road, Derby DE24 8ZF, United
 Kingdom
 Intertek Certification Limited is a
 UKAS accredited body under
 schedule of accreditation no. 014.



In the issuance of this certificate, Intertek assumes no liability to any party other than to the Client, and then only in accordance with the agreed upon Certification Agreement. This certificate's validity is subject to the organization maintaining their system in accordance with Intertek's requirements for systems certification. Validity may be confirmed via email at certification.validation@intertek.com or by scanning the code to the right with a smartphone. The certificate remains the property of Intertek, to whom it must be returned upon request.





Quali Middle East Association

MEMBERSHIP CERTIFICATION

This is to certify that

EXTRUCOAT 21
6TH OF OCTOBER CITY, GIZA, EGYPT

Membership Ref.: A043

is a member of the Quali Middle East Association and is a signatory to the policies and procedures related to the membership of the Association.

Period of validity of the certificate: until 31.12.2018

Dubai, 31 December 2017

QUALI MIDDLE EAST ASSOCIATION

Nasir Fahmeed
General Secretary

Mailing address: Quali Middle East Association
c/o Dubai Association Centre, ESO-24, T-19, 7th Floor
Sheikh Rashid Tower, Dubai World Trade Centre
Dubai, United Arab Emirates

P.O. Box 23070, Dubai-UAE
Phone: +971 4 309 7088
E-Mail: admin@qualimiddleeast.com
Internet: www.qualimiddleeast.com

QMEA License No: DAC-0039 issued by Dubai Chamber of Commerce & Industry

Authorization to use the quality sign



This is to certify that

EXTRUCOAT 21 FOR EXTRUDING ALUMINUM PROFILES

Piece Z13-T15, Engineering Square
Northern Expansions Industrial Zones
EG – 12566 6th of October City

Licence number: 1604

is authorized to use the quality sign which is shown above according to the REGULATIONS FOR THE USE OF THE QUALICOAT QUALITY SIGN FOR PAINT, LACQUER AND POWDER COATINGS ON ALUMINIUM FOR ARCHITECTURAL APPLICATIONS.

Date of issue of the licence: 11.08.2017
Period of validity of the licence: until 31.12.2018

Zurich, 31 October 2017

QUALICOAT

Mohammed C. Panam
President

CERTIFICATION BODY

Josef Schoppig
AC-Fiduciaire SA



Mailing address:
QUALICOAT, P.O. Box 1507, CH-8027 Zurich
Domicile:
QUALICOAT c/o AC-Fiduciaire SA, Tödistrasse 42, CH-8002 Zurich

Phone: +41 (0)43 305 09 70/79
Fax: +41 (0)43 305 09 98
E-mail: info@qualicoat.net
Internet: www.qualicoat.net

TV 400

Hinged System





Certificate of Approval

Extrucoat 21

is certified as an Approved Applicator to coat
Jotun Super Durable
 a product from Jotun Powder Coatings

This Company fulfils the requirements set by Jotun Powder Coatings for pre-treatment and application of powder coatings. These include having the necessary equipment, process controls and technical knowledge to comply with Jotun Powder Coatings' standards.



January 01, 2018
 (Certificate valid for one year from date above)

[Signature]
 Authorised Signatory
 Jotun Powder Coatings UAE (LLC)



Certificate of Approval

Extrucoat 21

is certified as an Approved Applicator to coat
Jotun Facade
 a product from Jotun Powder Coatings

This Company fulfils the requirements set by Jotun Powder Coatings for pre-treatment and application of powder coatings. These include having the necessary equipment, process controls and technical knowledge to comply with Jotun Powder Coatings' standards.



January 01, 2018
 (Certificate valid for one year from date above)

[Signature]
 Authorised Signatory
 Jotun Powder Coatings UAE (LLC)



Certificate of Approval

Extrucoat 21

is certified as an Approved Applicator to coat
Jotun Durasol
 a product from Jotun Powder Coatings

This Company fulfils the requirements set by Jotun Powder Coatings for pre-treatment and application of powder coatings. These include having the necessary equipment, process controls and technical knowledge to comply with Jotun Powder Coatings' standards.



January 01, 2018
 (Certificate valid for one year from date above)

[Signature]
 Authorised Signatory
 Jotun Powder Coatings UAE (LLC)

Interpon D Approved Applicator



Interpon D1000 Series

Extrucoat 21 for producing coloring aluminium profiles

3rd Industrial area, piece 576, 6th of October.
Giza, Egypt.

Has fulfilled AkzoNobel's tests and inspection regarding the pre-treatment, the application, the quality management standards, the procedures and complies with the requirements of the Architectural Range Approved Applicator schedule.

This certificate is effective from
17th October 2017 to 16th October 2018

Approved for Aluminium Alloys AA6063
Approved for Pre-treatment Type Chrome

Wael Mahmoud
Regional Export & Marketing Manager
Near East & East Africa

Date 17/10/2017
Certification number N° EGY09D1

AkzoNobel Powder Coatings S.A.E

Interpon.
POWDER COATINGS

AkzoNobel

Interpon D Approved Applicator



Interpon D2000 Series

Extrucoat 21 for producing coloring aluminium profiles

3rd Industrial area, piece 576, 6th of October.
Giza, Egypt.

Has fulfilled AkzoNobel's tests and inspection regarding the pre-treatment, the application, the quality management standards, the procedures and complies with the requirements of the Architectural Range Approved Applicator schedule.

This certificate is effective from
30th October 2017 to 29th October 2018

Approved for Aluminium Alloys AA6063
Approved for Pre-treatment Type Chrome

Wael Mahmoud
Regional Export & Marketing Manager
Near East & East Africa

Date 30/10/2017
Certification number N° EGY09D2

AkzoNobel Powder Coatings S.A.E

TV 400

Hinged System

SPECIFICATION TECHNIQUE TECHNICAL SPECIFICATION

PROFILS:

Ce système a été étudié et conçu par Alceo, pour la fabrication de fenêtre à frappe et coulissante. Il utilise les dernières technologies d'assemblage et de fabrication. Ce nouveau système est en conformité avec le standard Européen.

NORMES PRINCIPALES:

Etudes et production: NF P24-101, NF P24-301, XP P24-400 et 401

Test et classification: NF EN 1026, NF EN 1027, NF EN 12211, NF EN 12207, NF EN 12208, NF EN 12210.

Performances thermiques et acoustiques: NF EN 410, NF EN 673, NF EN ISO 10077-1, PR EN 13947, NF EN ISO 140-4 et NF EN ISO 140-5.

MATIERE:

Le profil extrudé est en alliage d'aluminium (Al Mg Si) 6060 (norme NF EN 573-3, NF EN 755-1 and 2). Les tolérances sont conformes à la norme NF EN 12020-1 et 2).

TRAITEMENT THERMIQUE:

T4-T5-T6

PROTECTION:

Classe d'anodisation :
classe 15 (15-20 microns)
Classe 20 (20-25 microns) en option
L'anodisation est conforme au label qualité QUALANOAD EWWA/EURAS

ACCESSOIRES:

Tous les accessoires, produits et joints sont conçus pour le système Alceo.
Utilisation de matériaux de haute qualité.
Visserie: Acier inoxydable 18/10
Joint: EPDM
Autres: Polyamide, Zamack, Fonte d'aluminium

PROFILES:

This system studied and designed by Alceo is specific for hinged and sliding windows. Using the last technology for fixing and manufacturing operation. This new system is in conformance with French European standard.

MAIN NORMS:

Study and production: NF P24-101, NF P24-301, XP P24-400 and 401

Test and classification: NF EN 1026, NF EN 1027, NF EN 12211, NF EN 12207, NF EN 12208, NF EN 12210.

Thermic and noise performance: NF EN 410, NF EN 673, NF EN ISO 10077-1, PR EN 13947, NF EN ISO 140-4 and NF EN ISO 140-5.

MATERIAL:

The extracted profile are in aluminum alloy (Al Mg Si) 6060 (norm NF EN 573-3, NF EN 755-1 and 2). All tolerance are specific norm NF EN 12020-1 and 2).

THERMICAL TREATMENT:

T4-T5-T6

PROTECTION:

Anodized class 15 (15-20 microns)
Class 20 (20-25 microns) in option
Anodisation will be conforms to the quality label QUALANOAD EWWA/EURAS

ACCESSORIES:

All accessories, hardware or gaskets are designed for Alceo system.
High quality material using.
Screw: Stainless steel 18/10
Gasket: EPDM
Other: Polyamide, Zamack, Cast aluminum

SPECIFICATION TECHNIQUE TECHNICAL SPECIFICATION (suite)

CONCEPT PRODUIT:

Coulissant, frappe de type traditionnel.

CADRE FIXE:

Le cadre fixe est de forme tubulaire

CHASSIS OUVRANT:

Coté et montant central sont de forme tubulaire.

ASSEMBLAGE:

Cadre dormant : Coupe a 45° assemblé par equerres vissées.

Cadre ouvrant : Coupe a 45° assemblé par equerres vissées.

VITRAGE :

Simple ou double vitrage, de 6 mm a 22 mm maintenu par des joints en EPDM clippé sur le panneau avec un prise en feuillure minimum de 20mm. Le chassis doit être monté à l'intérieur de la maçonnerie.

ETANCHEITE:

L'étanchéité est assurée par un joint central en EPDM. Une seconde barrière est incluse dans le dormant au centre du châssis (frappe). ; les joints sont en EPDM, ou Silicone.

Les fenêtres et les portes, assure un excellent drainage.

CONCEPT PRODUIT:

Sliding windows, window doors , traditional

FIXED FRAMES:

Fixed frame of form design and tubular section.

OPENING FRAMES:

Side and central of form design and tubular section.

ASSEMBLY:

Door frames: out of cut of mitre by squares with pawn.

Opening: out of cut of mitre by squares with pawn.

GLAZING:

Simple or insulator of 6 with 22 mm maintained by joints in EPDM and a clipped panel a height minimum of 20mm (bottom of feuillure). The panel must obligatorily be with dimensions interior of construction

SEALING:

The sealing is guaranteed by a central sealing gasket in EPDM-ASTM tested. A second barrier, constituted by a sealing gasket, is on the flap by the inside overlap. Glazing is done with EPDM sealing gasket or silicone.

The windows and the door producers must guarantee an efficient drainage.

Material data sheet

Insulating strips of PA 66 GF25
- dry impact resistant -

No.	Characteristic	Reference standard	Unit	Samples prepared from extruded insulating strips		Injection-moulded samples
				Dry ¹⁾	equilibrium ⁽²⁾ moisture content	Dry ¹⁾
1	melting temperature	EN ISO 11357-3	°C	min. 250 ⁽³⁾	min. 250 ⁽³⁾	min. 250 ⁽³⁾
2	density	EN ISO 1183-1 or -3	g/cm ³	1,3 +/- 0,05	1,3 +/- 0,05	1,3 +/- 0,05
3	annealing residue (glass fibre content)	EN ISO 1172	%	25 +/- 2,5	25 +/- 2,5	25 +/- 2,5
4	shore hardness D	EN ISO 868		82 +/- 4 ⁽⁴⁾	78 +/- 4 ⁽⁴⁾	84 +/- 2
5	impact strength	EN ISO 179-1	kJ/m ²	min. 30 or without break ⁽⁵⁾	min. 40 or without break ⁽⁵⁾	min. 35 ⁽⁶⁾
6	tensile strength	EN ISO 527-2 and -4	N/mm ²	min. 80 ⁽⁷⁾	min. 50 ⁽⁷⁾	min. 110 ⁽⁸⁾
7	Young's modulus	EN ISO 527-2 and -4	N/mm ²	min. 4500 ⁽⁷⁾	min. 2000 ⁽⁷⁾	min. 6000 ⁽⁸⁾
8	elongation at break	EN ISO 527-2 and -4	%	min. 3 ⁽⁷⁾	min. 7 ⁽⁷⁾	min. 3 ⁽⁸⁾

- 1) Sample water content less than %0,2 by weight
- 2) Fast conditioning acc. to EN ISO °23) 1110C / %50)
- 3) Maximum temperature °300C
- 4) Specimen thickness 2mm, unstacked
- 5) Specimen Typ 2fU (50 mm x 10 mm x 2mm)
- 6) Specimen Typ 1fU (80 mm x 10 mm x 4mm)
- 7) Specimen Typ 1BA
- 8) Specimen Typ 1A

In case of specific questions we gladly offer our individual support.



Energieeinsparung beginnt mit Technoform

Seit mehr als 30 Jahren entwickeln und produzieren wir für unsere Kunden hochpräzise Isolierprofile, die in Fenstern, Türen und Fassaden aus Aluminium für die thermische Trennung sorgen. Täglich arbeiten wir mit unseren Kunden an neuen, noch besseren Lösungen zur Einsparung von Energie und CO₂-Emissionen.

- Weltweit haben wir bis heute rund 1,8 Mrd. Meter Isolierstege verkauft
- In ca. 90 Mio. Fenstern sparen sie rund 9 Mrd. kWh Energie pro Jahr und reduzieren damit den CO₂-Ausstoß erheblich
- Bei 10 Cent Energiekosten pro kWh werden global 900 Mio. € eingespart, die man für andere Dinge sinnvoller ausgeben kann – Jahr für Jahr.

Energy-Saving starts with Technoform

For over 30 years we have been developing and producing high precision insulating strips for our customers; strips which provide thermal insulation in aluminium windows, doors and facades. Every day we are working with our customers to develop new improved solutions to reduce energy consumption and CO₂-emissions even further.

- To date we have sold 1.8 billion metres of insulating strips globally.
- In about 90 million windows, they save energy amounting to almost 9 billion kilowatt hours per year and thus reduce CO₂-emissions considerably.
- Based on a ten euro-cent cost per kilowatt hour, 900 million € are saved globally which can be put to better use. Every year.

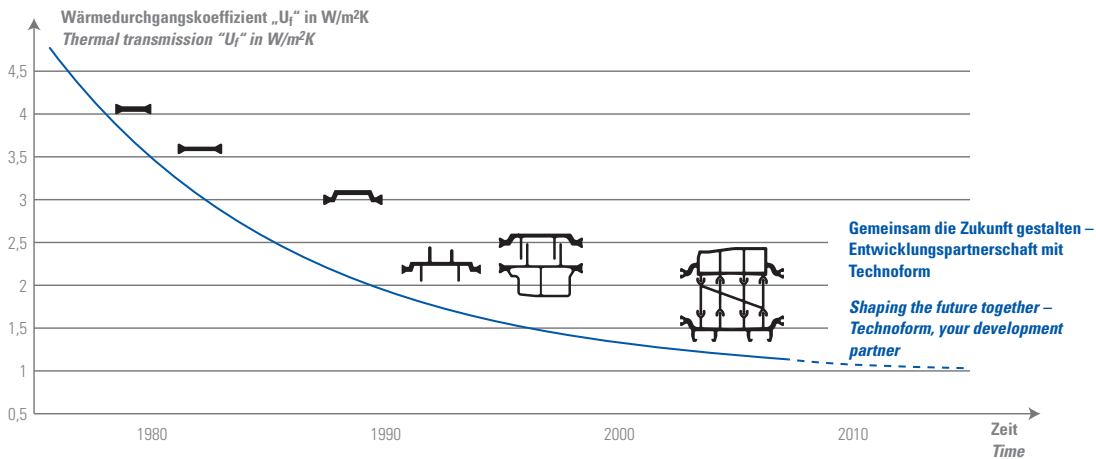
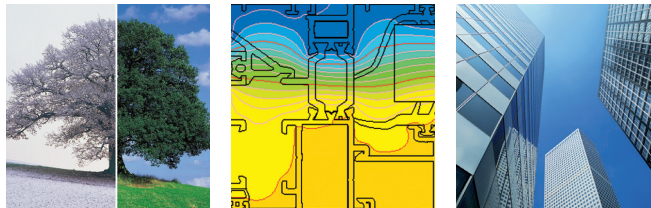

Vom einfachen Isoliersteg zur komplexen Isolierzone – Entwicklungspartnerschaft mit Technoform

Steigende Anforderungen und neue Entwicklungen stellen uns und unsere Kunden täglich vor neue Herausforderungen. Herausforderungen, die Technoform Bautec seit über 30 Jahren erfolgreich annimmt. Als kompetenter Entwicklungspartner ist es unser Ziel, auch in Zukunft gemeinsam mit unseren Kunden optimale Lösungen für die thermische Trennung in Aluminiumfenstern, -türen und -fassaden zu entwickeln. Nutzen Sie die Entwicklungspartnerschaft mit Technoform Bautec, um führende Systeme am Markt anbieten zu können.

From straightforward insulating profiles to a complex insulating zone – Technoform your development partner

Ever increasing requirements and cutting-edge developments pose challenges to our customers on a regular basis. Challenges that we at Technoform have been taking on successfully for over 30 years. As a skilled consulting partner it is our aim to continue developing optimum solutions for thermal insulation in aluminium windows, doors and facades together with our customers. Use Technoform Bautec's development partnership to place leading systems on the market.

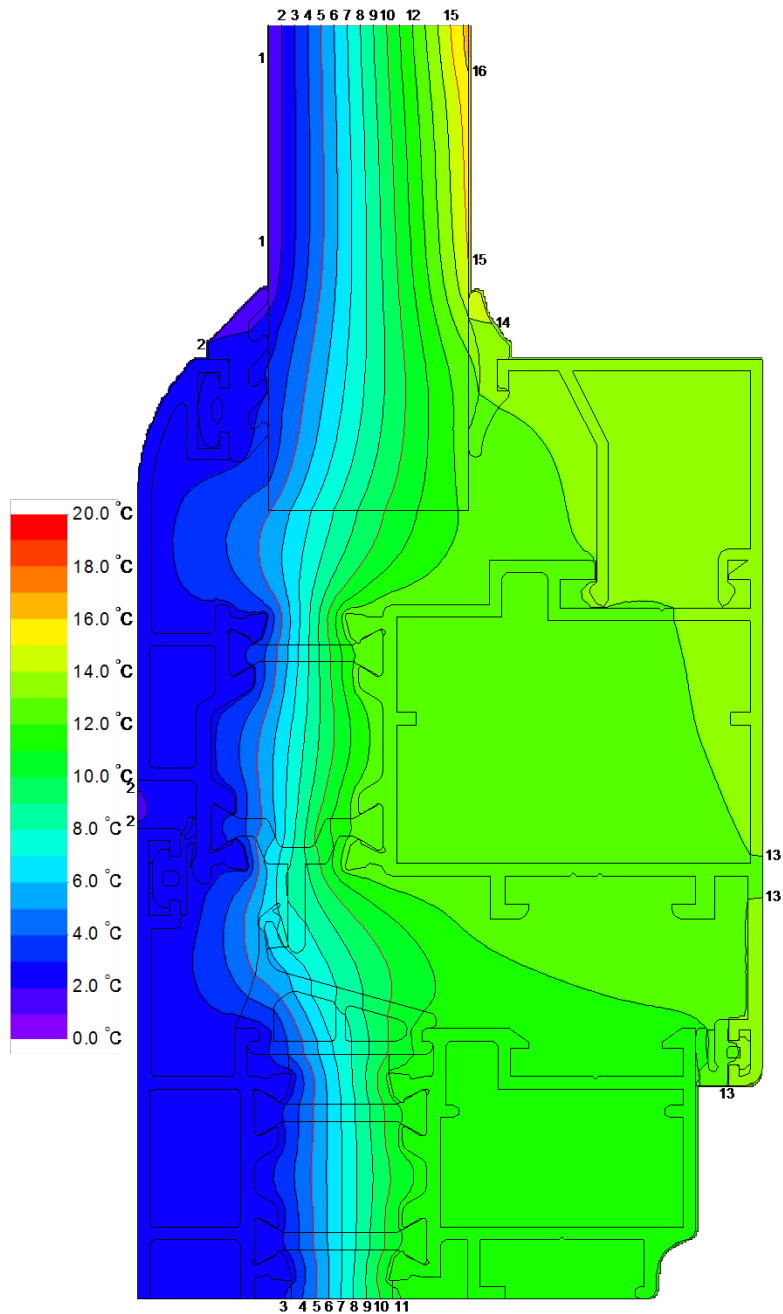

$$U_{fAB} = \frac{\frac{\Phi}{\Delta T} - U_p \cdot b_p}{b_f} = \frac{\frac{11.530}{20.000} - 1.299 \cdot 0.190}{0.098} = 3.35 \text{ W}/(\text{m}^2 \cdot \text{K})$$

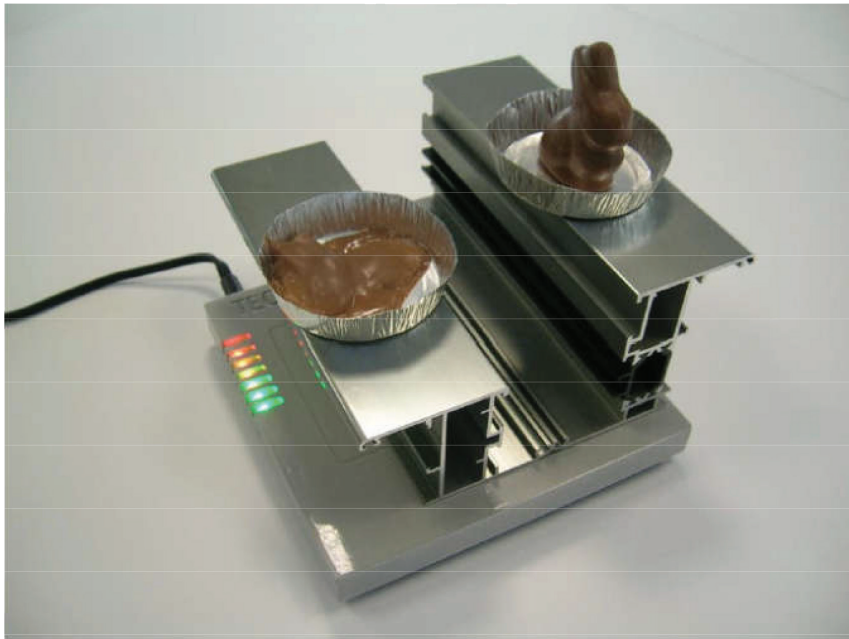

TV 400

Hinged System

POWERED BY



Check For Deflection at the Middle Section of window (Volcano hinged System)

Window size is:(2000mm Width X 2200mm Height)

Beam Statics - Vertical Germany EN 1991-1-4/NA:2010-12

Parameter

Unit (Length): m

Installation Height of Element: m (Upper Edge, Max/ 100 m)

Calculation

Ix due to Wind Pressure: 29.1 cm⁴ (0.80 kN/m²)
 Ix due to Wind Suction: 29.1 cm⁴ (0.80 kN/m²)
Required Ix-Value: 29.1 cm⁴

Design (Deflection)

Allowed Glass: Min(15.0mm | L/200 = 11.0mm) = 11.0 mm
 Allowed Beam (Ix)Min(15.0 mm | L/200 = 11.0 mm) = 11.0 mm

Decisive Glass: 4.3 mm <= 11.0 mm
 Decisive Rate of Utilisation: 39.1%

System

1-Span Beam 2-Span Beam Load Distrib/ Area 1SB Multi-Span Beam

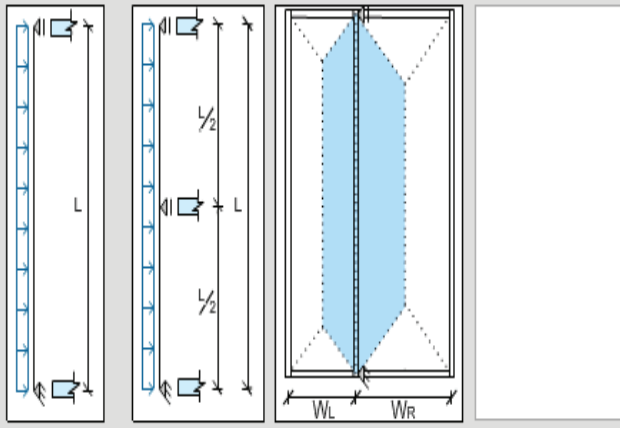

Length (L): m
 Field Width Left (wL): m
 Field Width Right (wR): m

Free Ix-Value: cm⁴

Modulus of Elasticity: 70000 N/mm² (Aluminium)

Selected Section: VOLCANO MIDDLE PROFILE 74.4 cm⁴

Deflection Line

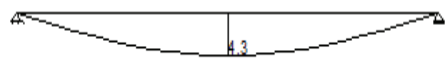

Moment Diagram

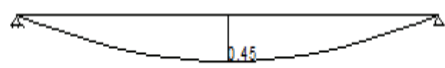

Shear Diagram



EN 1991-1-4/NA:2010-12

1. Wind Load Calculation:

Installation Height $z = 46 \text{ m}$

$w_e(46\text{m}) = +0.80 \text{ kN/m}^2$

2. System and Load

E-Modulus: $E = 70000 \text{ N/mm}^2$

Selected Section: VOLCANO MIDDLE PROFILE, $I_x = 74.4 \text{ cm}^4$

Load [kN/m]

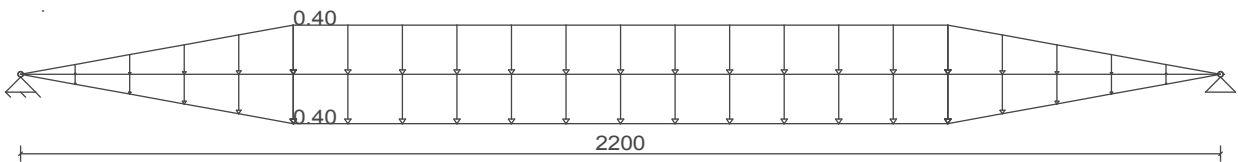

3. Internal Forces

Support Reaction [kN]



Shear Force [kN]

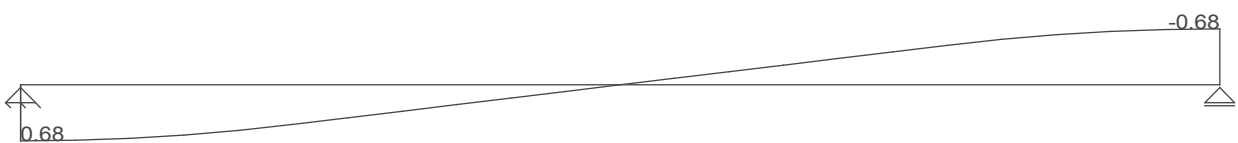

Moment [kNm]

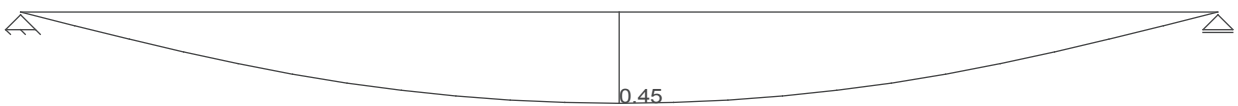

Deflection [mm]

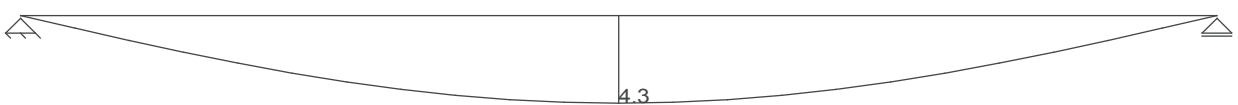

Maximum Deflection: 4.3 mm

TV400

Hinged System

4. Design

Selected Section: VOLCANO MIDDLE PROFILE, $I_x = 74.4 \text{ cm}^4$

Serviceability Limit State:

allowed w (Glass Edge) = $\min(15.0 \text{ mm} \mid L_G/200 = 11.0 \text{ mm}) = 11.0 \text{ mm}$

allowed w (Beam) = $\min(15.0 \text{ mm} \mid L_B/200 = 11.0 \text{ mm}) = 11.0 \text{ mm}$

Structural Analysis:

current $w_G = 4.3 \text{ mm} \leq$ allowed $w_G = 11.0 \text{ mm}$ and current $w_B = 4.3 \text{ mm} \leq$ allowed $w_B = 11.0 \text{ mm}$ and current $I_x = 74.4 \text{ cm}^4 \geq$ required $I_x = 29.1 \text{ cm}^4$, Rate of Utilisation $\eta = 39.1 \%$, glass edge decisive

Beam Span					
Z_e [m]	L_B [mm]	allowed w_B [mm]	current w_B [mm]	η_{B} [%]	
46.000	2200	11	4.3	39.1	
Glass Span					
Z_e [m]	L_G [mm]	allowed w_G [mm]	current w_G [mm]	η_{G} [%]	
46.000	2200	11	4.3	39.1	

Section Properties for Middle Profile at The Hinged System

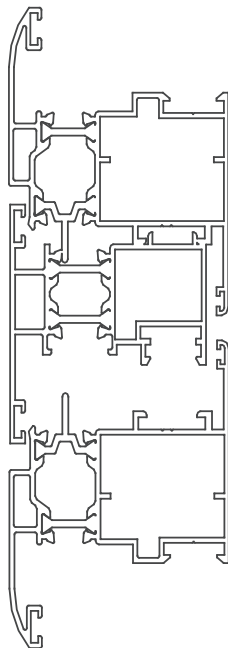

Area:	16.4476
Perimeter:	212.0451
Bounding box:	X: -2.7217 -- 3.8496
	Y: -8.0915 -- 7.7377
Centroid:	X: 0.0000
	Y: 0.0000
Moments of inertia:	X: 225.8495
	Y: 74.3979
Product of inertia:	XY: -0.0580
Radii of gyration:	X: 3.7056
	Y: 2.1268
Principal moments and X-Y directions about centroid:	
	I: 225.8495 along [1.0000 -0.0004]
	J: 74.3978 along [0.0004 1.0000]

Check For Deflection at the Middle Section of window (Volcano hinged System)

Window size is:(2000mm Width X 1800mm Height)

Beam Statics - Vertical Germany EN 1991-1-4/NA:2010-12

Parameter

Unit (Length):

Installation Height of Element: m (Upper Edge, Max/ 100 m)

Calculation

Ix due to Wind Pressure: 15.3 cm⁴ (0.80 kN/m²)
 Ix due to Wind Suction: 15.3 cm⁴ (0.80 kN/m²)
Required Ix-Value: 15.3 cm⁴

Design (Deflection)

Allowed Glass: $\text{Min}(15.0\text{mm} | L/200 = 9.0\text{mm}) = 9.0\text{ mm}$
 Allowed Beam (Ix): $\text{Min}(15.0\text{ mm} | L/200 = 9.0\text{ mm}) = 9.0\text{ mm}$

Decisive Glass: 7.9 mm \leq 9.0 mm
 Decisive Rate of Utilisation: 88.2%

System

1-Span Beam
 2-Span Beam
 Load Distrib/ Area ISB
 Multi-Span Beam

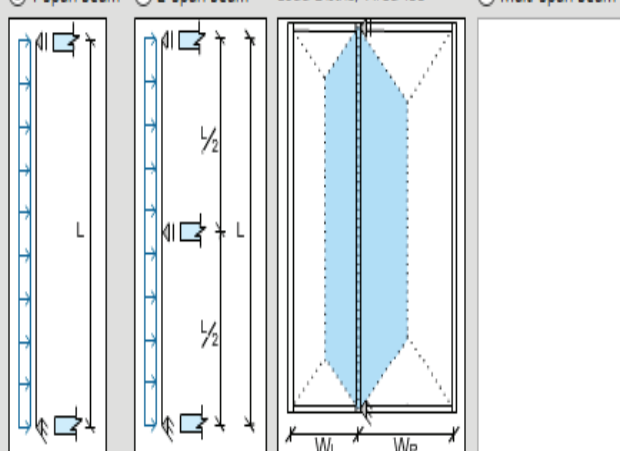

Length (L): m
 Field Width Left (wL): m
 Field Width Right (wR): m

Free Ix-Value: cm⁴

Modulus of Elasticity: 70000 N/mm² (Aluminium)

Selected Section: VOLCANO MIDDLE PROFILE 17.3 cm⁴

Deflection Line



Moment Diagram

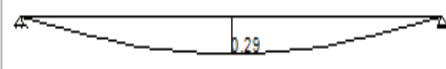

Shear Diagram

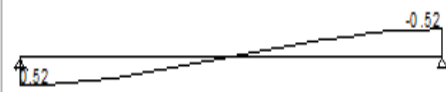

Print Close

Beam Statics - Vertical

EN 1991-1-4/NA:2010-12

1. Wind Load Calculation:

Installation Height $z = 40$ m

$$w_e(40m) = +0.80 \text{ kN/m}^2$$

2. System and Load

E-Modulus: $E = 70000 \text{ N/mm}^2$

Selected Section: VOLCANO MIDDLE PROFILE, $I_x = 17.3 \text{ cm}^4$

Load [kN/m]

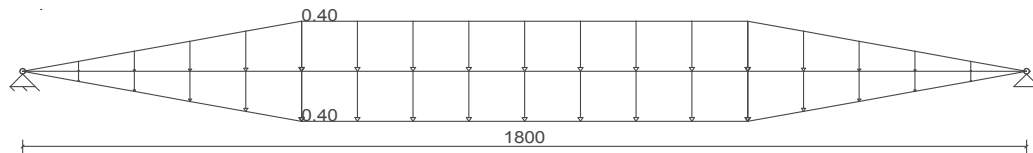

3. Internal Forces

Support Reaction [kN]



Shear Force [kN]



Moment [kNm]



Deflection [mm]

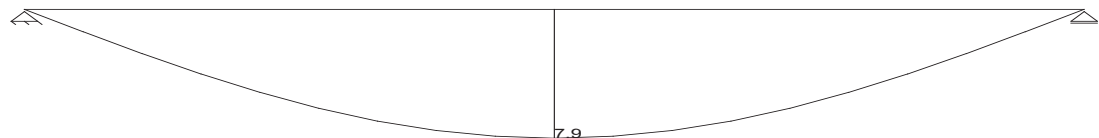





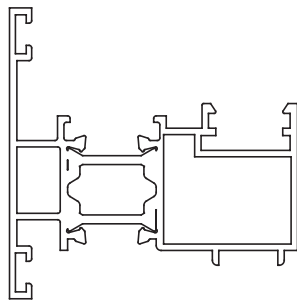



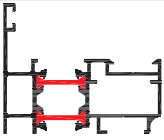
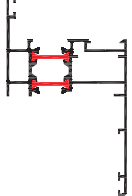
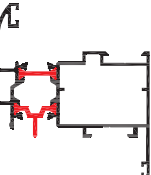
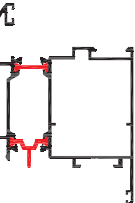
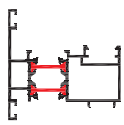
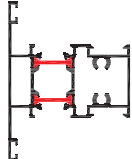
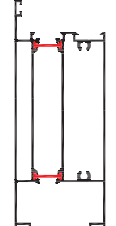
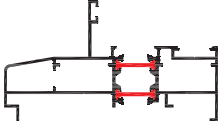

Maximum Deflection: 7.9 mm

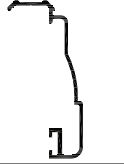
Section Properties for Middle Profile at The Hinged System:

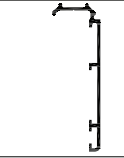

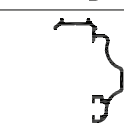
Area: 4.8988
 Perimeter: 61.7090
 Bounding box: X: -2.3543 -- 3.4981
 Y: -2.4523 -- 3.4476
 Centroid: X: 0.0000
 Y: 0.0000
 Moments of inertia: X: 6.9252
 Y: 17.1449
 Product of inertia: XY: -1.3914
 Radii of gyration: X: 1.1890
 Y: 1.8708
 Principal moments and X-Y directions about centroid:
 I: 6.7391 along [0.9912 -0.1325]
 J: 17.3310 along [0.1325 0.9912]

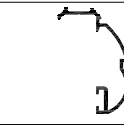
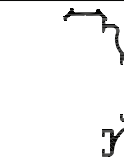
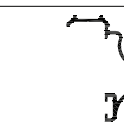
Profile	Shape	Description	Weight kg/m	Ix-x cm ⁴	Iy-y cm ⁴
TV 4100		FRAME	1.126	15.478	4.984
TV 4101		FRAME WITH ARCHITRAVE	1.319	25.411	9.120
TV 4200		WINDOW SASH	1.395	31.562	11.138
TV 4201		DOOR SASH	1.708	37.802	17.7604
TV 4202		DOUBLE LEAF ADAPTOR	1.189	17.331	6.739
TV 4300		TRANSOM	1.495	21.317	13.835
TV 4301		DOOR BOTTOM RAIL	2.686	180.349	43.442
TV 4302		FIXED	1.481	40.59	6.89
TV 4400		DOUBLE GLAZING BEED	0.273	0.292	0.564
TV 4401		SINGLE GLAZING BEED	0.335	2.155	0.63

Profile	Shape	Description	Weight kg/m	Ix-x cm ⁴	Iy-y cm ⁴
DW 12300		DECORATIVE ARCHITRAVE 50MM	0.369		
DW 12301		DECORATIVE ARCHITRAVE 34MM	0.295		
DW 12302		FLAT ARCHITRAVE 50MM	0.307		
DW 12303		FLAT ARCHITRAVE 34MM	0.237		
DW 12304		ARCHITRAVE 50MM	0.357		
DW 12305		ARCHITRAVE 34MM	0.280		
DW 12308		ROUND ARCHITRAVE 50MM	0.365		
DW 12309		ROUND ARCHITRAVE 34MM	0.298		
DW 12310		CUREVED ARCHITRAVE 50MM	0.355		
DW 12311		CUREVED ARCHITRAVE 34MM	0.273		
DW 44500		CREMONE PROFILE	0.175		

CODE	DRAWING	DESCRIPTION	MATERIAL
WH-620-05		PORTOGUESE CREMON HANDEL	ALUMINIUM
06-2701-03A		PORTOGUESE HINGE	ALUMINIUM
BOLT-1542		FLASH BOLT	PVC
KIT-10451-CH		LOCKING KIT	PVC
01-4160		CORNER JOINT FOR SASH	ALUMINIUM
01-4161		CORNER JOINT FOR FRAME	ALUMINIUM
AVR.20300		CENTRAL GASKET	EPDM
AVR.02260		STRIKER GASKET	EPDM
AVR.03'		GLASS GASKET 3MM	EPDM

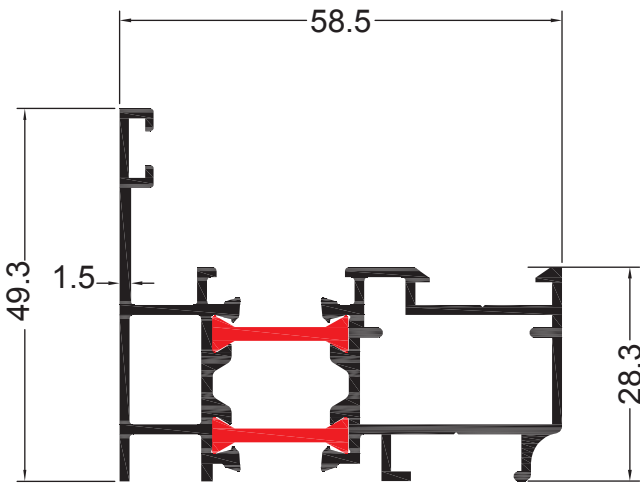

TV 4100
1.126 KG/M

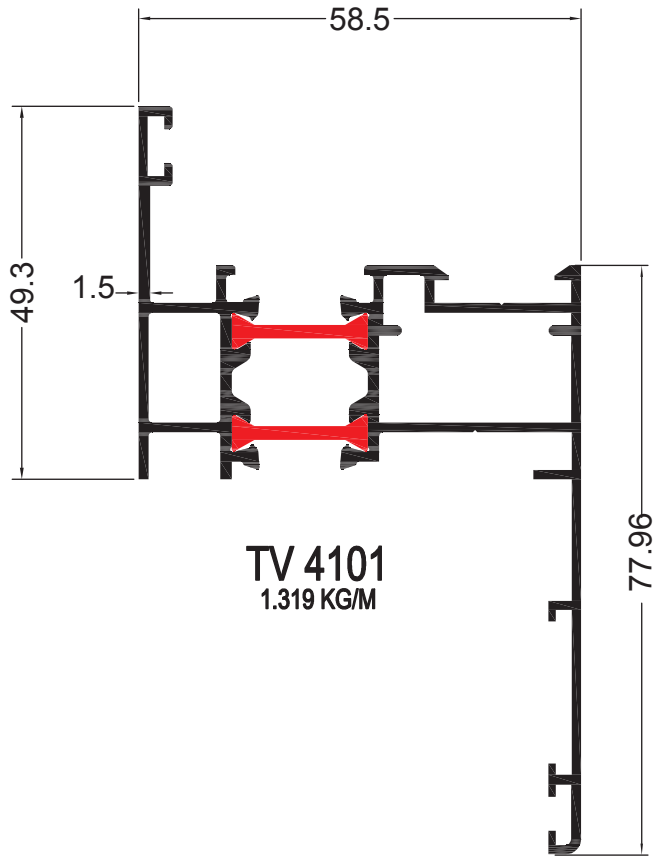

TV 4101
1.319 KG/M

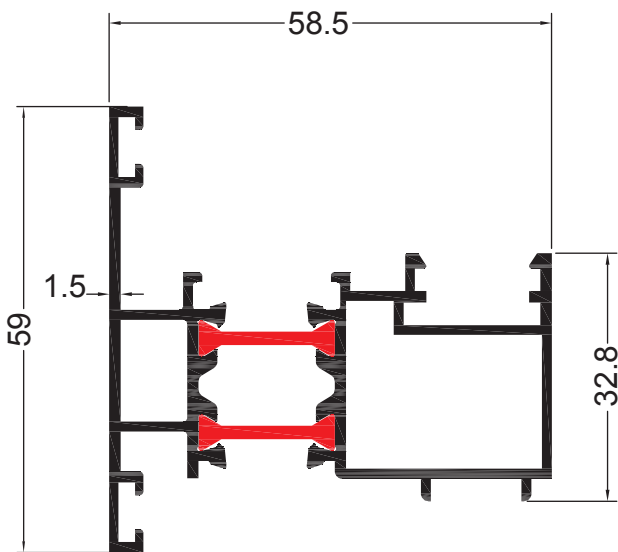

TV 4202
1.189 KG/M

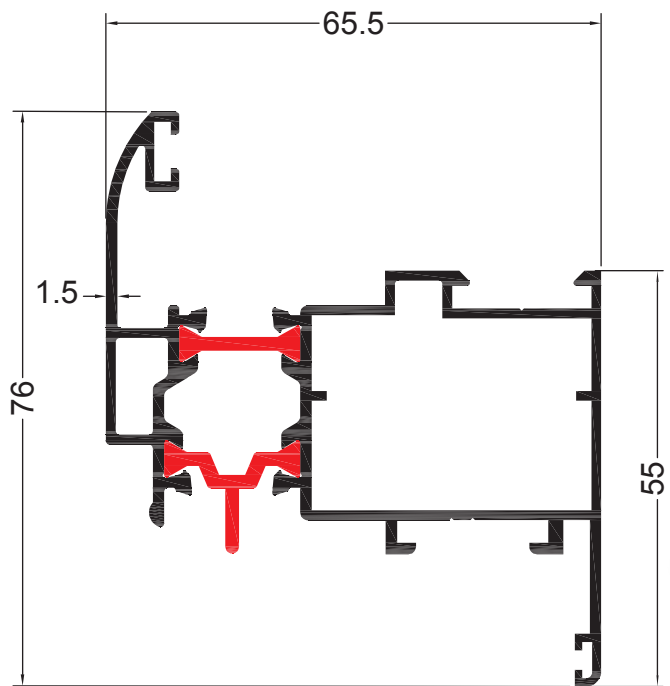

TV 4200
1.395 KG/M

TV 400

Hinged System

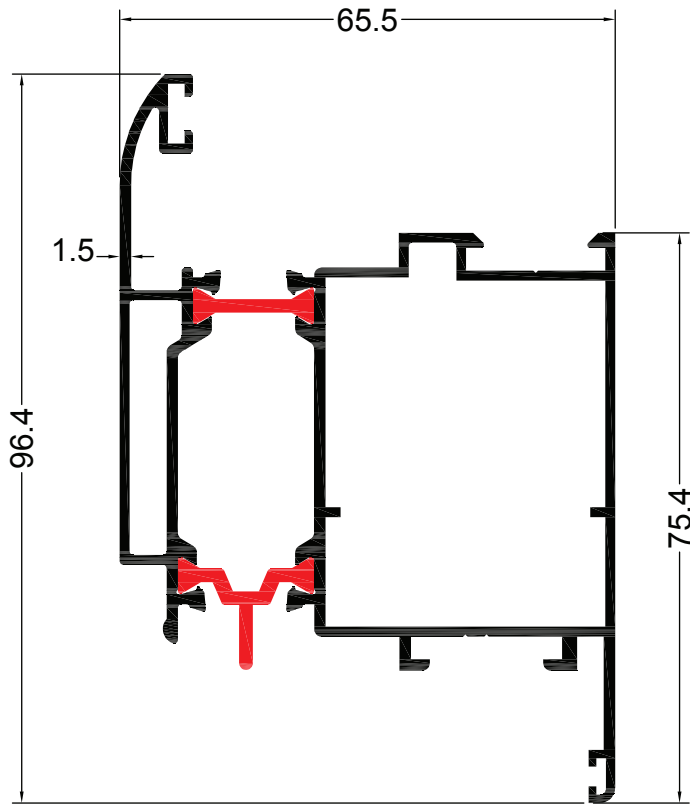

TV 4201
1.708 KG/M

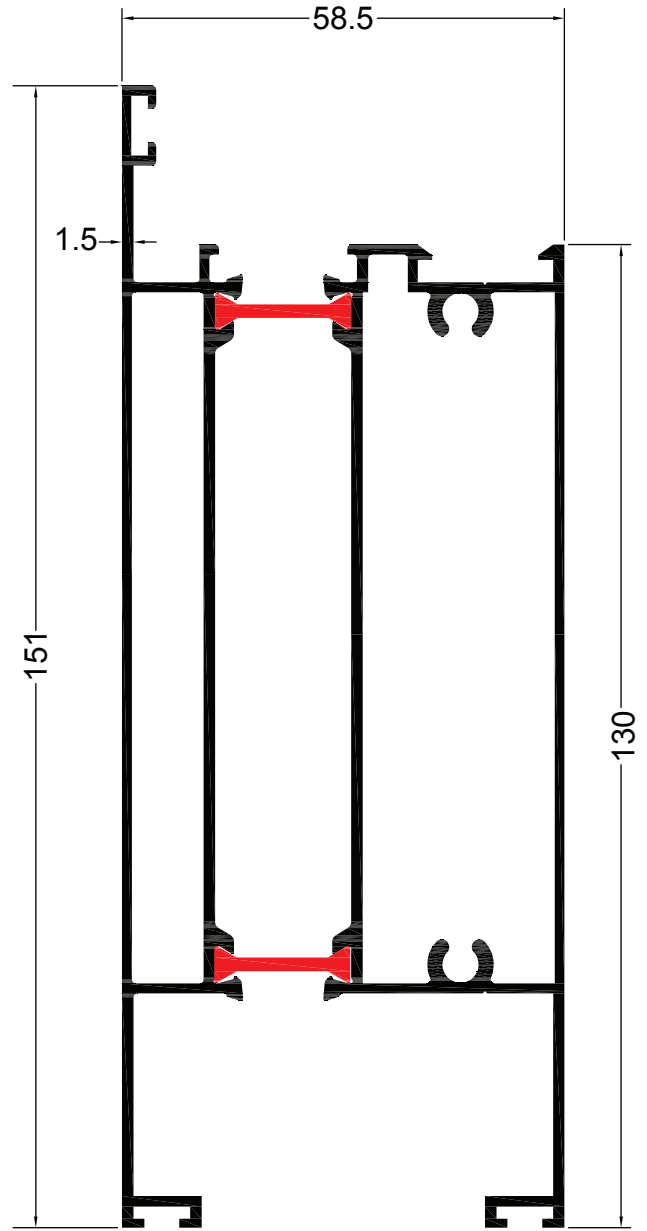

TV 4301
2.686 KG/M

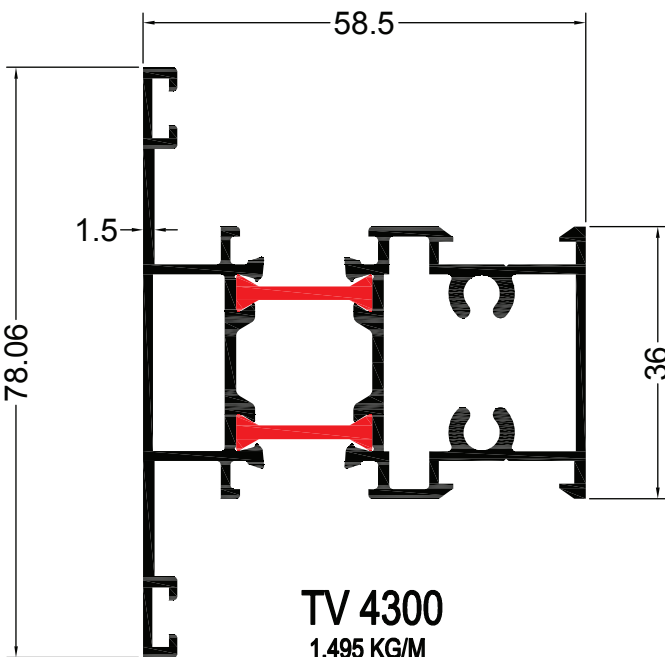

TV 4300
1.495 KG/M

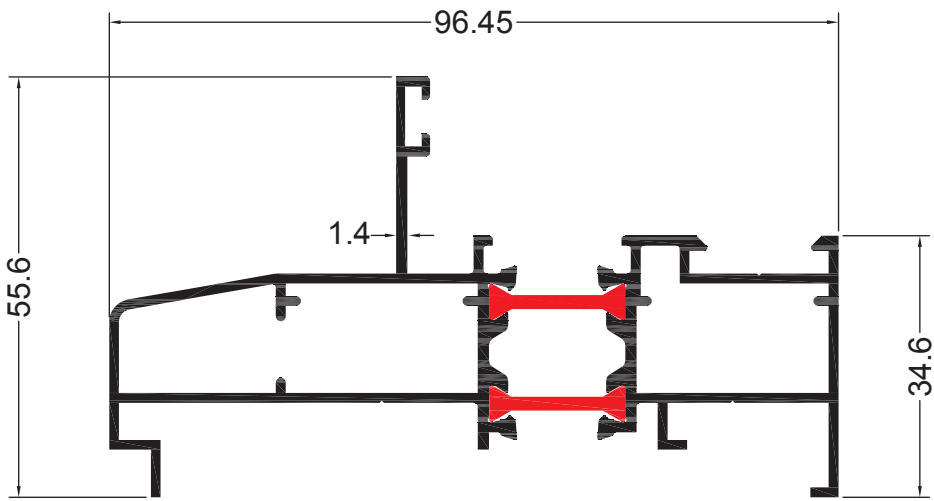

TV 4302
1.481 Kg/m.

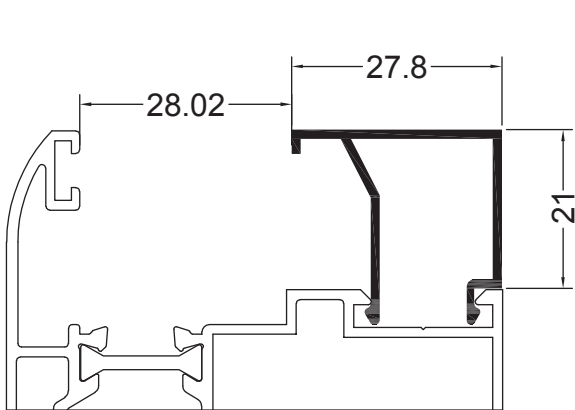

TV 4400
0.273 KG/M

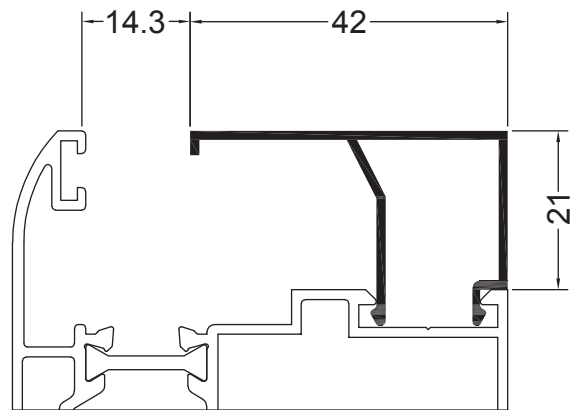

TV 4401
0.335 KG/M

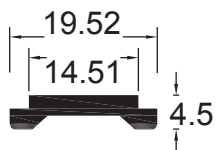

DW 44500
0.175 Kg/m

TV 400

Hinged System

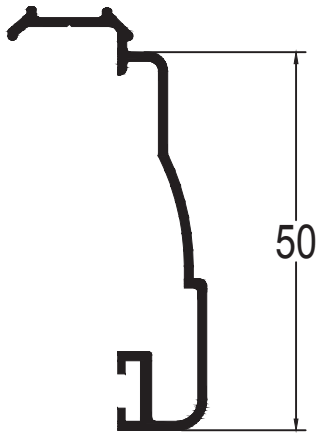

DW 12300
0.369 Kg/m.

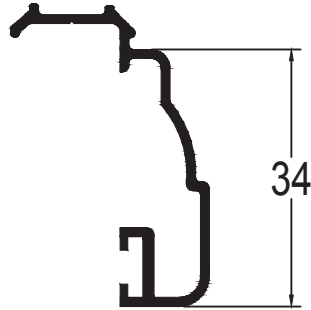

DW 12301
0.295 Kg/m.

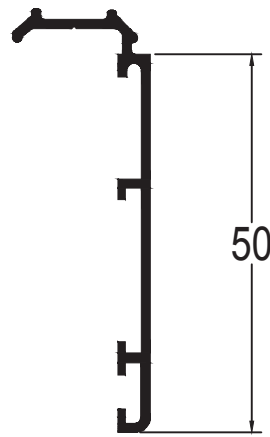

DW 12302
0.307 Kg/m.

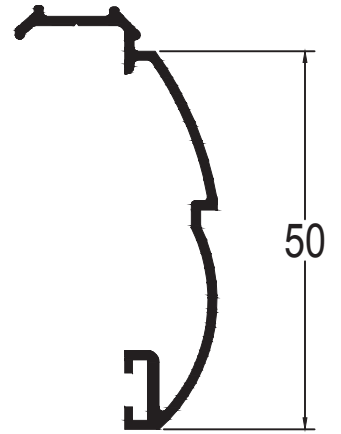

DW 12308
0.365 Kg/m.

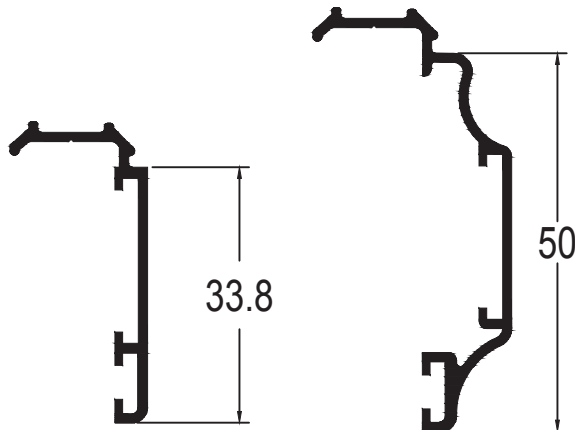

DW 12303
0.237 Kg/m.

DW 12304
0.357 Kg/m.

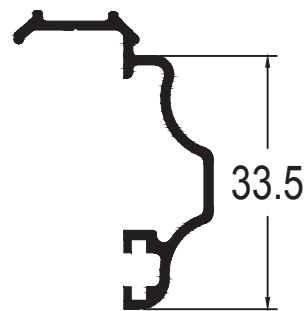

DW 12305
0.280 Kg/m.

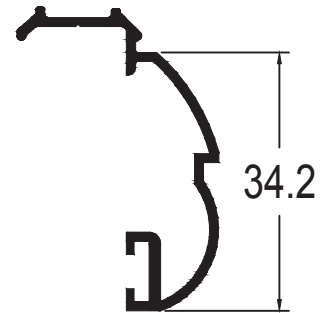

DW 12309
0.298 Kg/m.

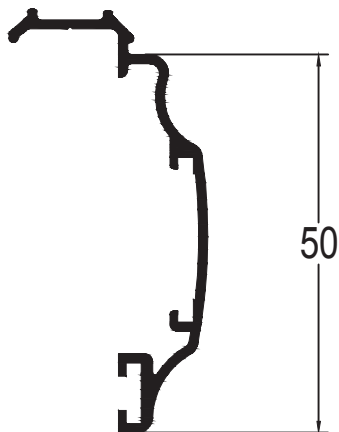

DW 12310
0.355 Kg/m.

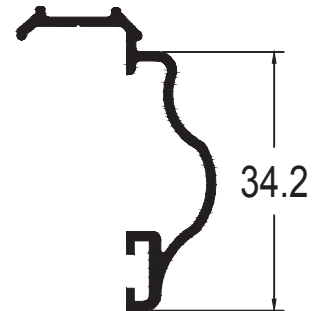

DW 12311
0.273 Kg/m.

Fenêtre 1 Vantail

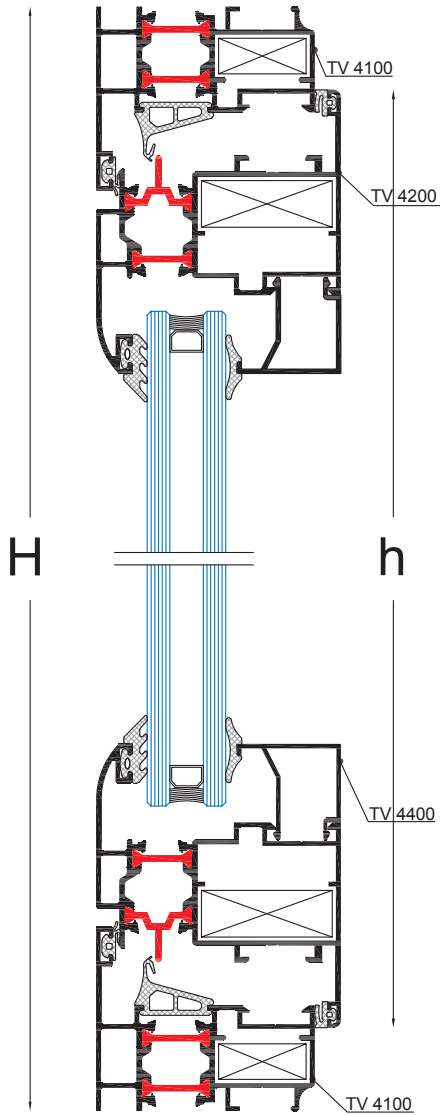

COUPE B - B

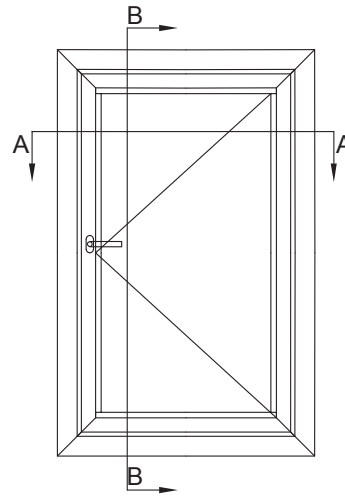

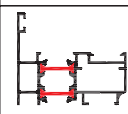
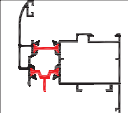
CUTTING LIST			
Shape	Prof. No	QTY	CUTTING LENGTH (mm)
	TV 4100	2	L
		2	H
	TV 4200	2	L-45
		2	H-45
GLASS		1	L-153
			H-153

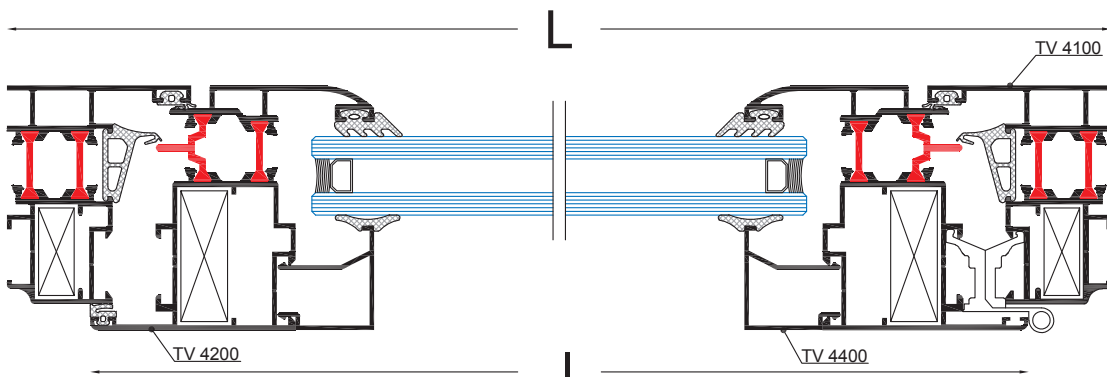

COUPE A - A

TV 400

Hinged System

Fenêtre 2 Vantaux

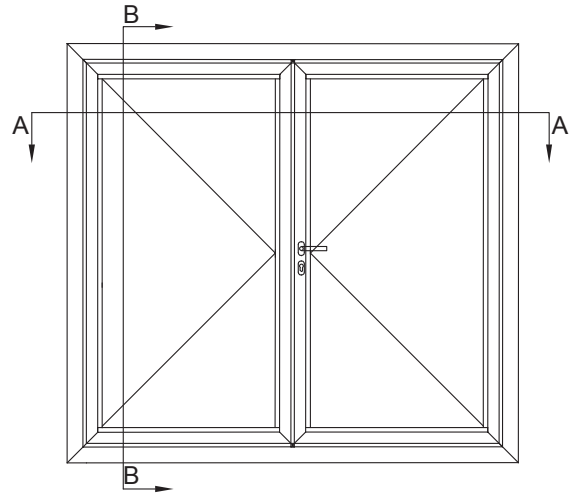
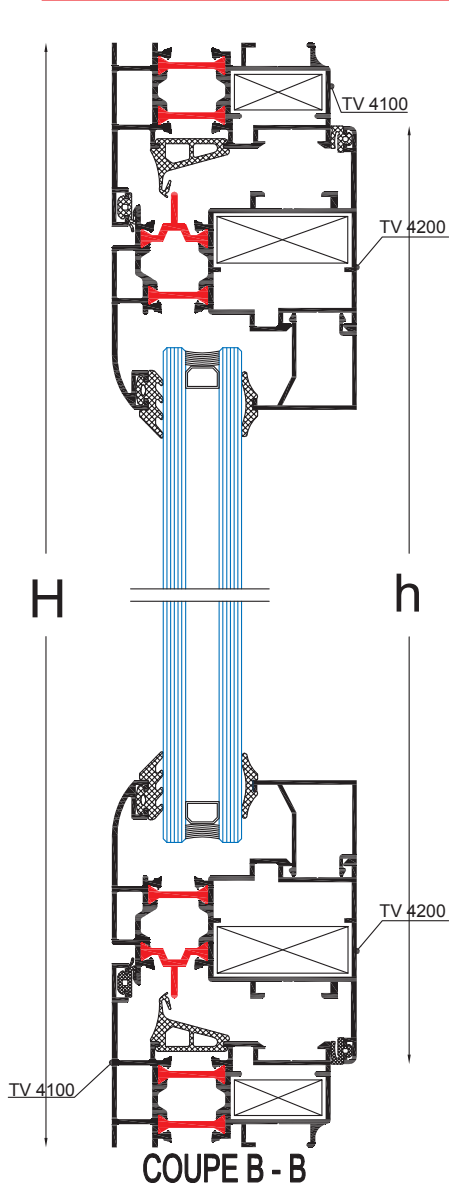

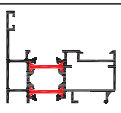
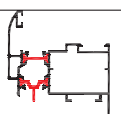
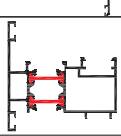
CUTTING LIST			
Shape	Prof. No	QTY	CUTTING LENGTH (mm)
	TV 4100	2	L
		2	H
	TV 4200	4	$\frac{L-50}{2}$
		4	H-45
	TV 4202	1	H-57
GLASS		2	$\frac{L-266}{2}$
			H-153

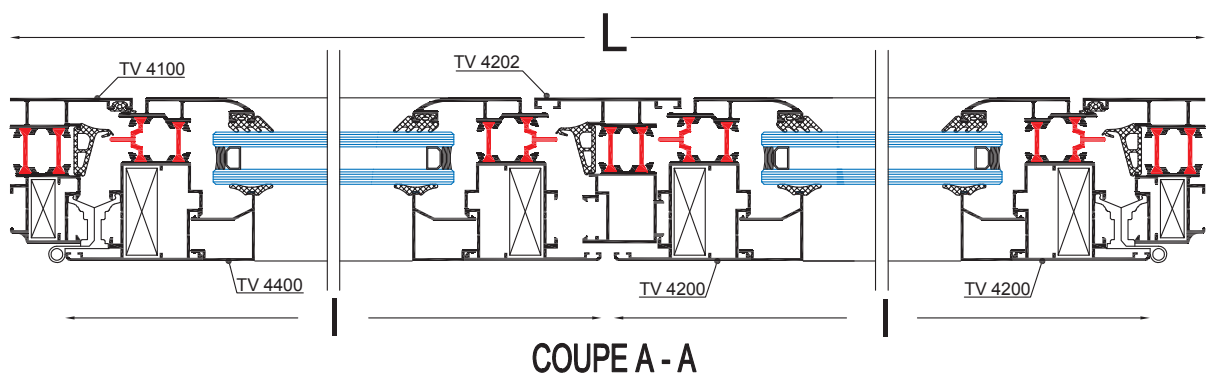

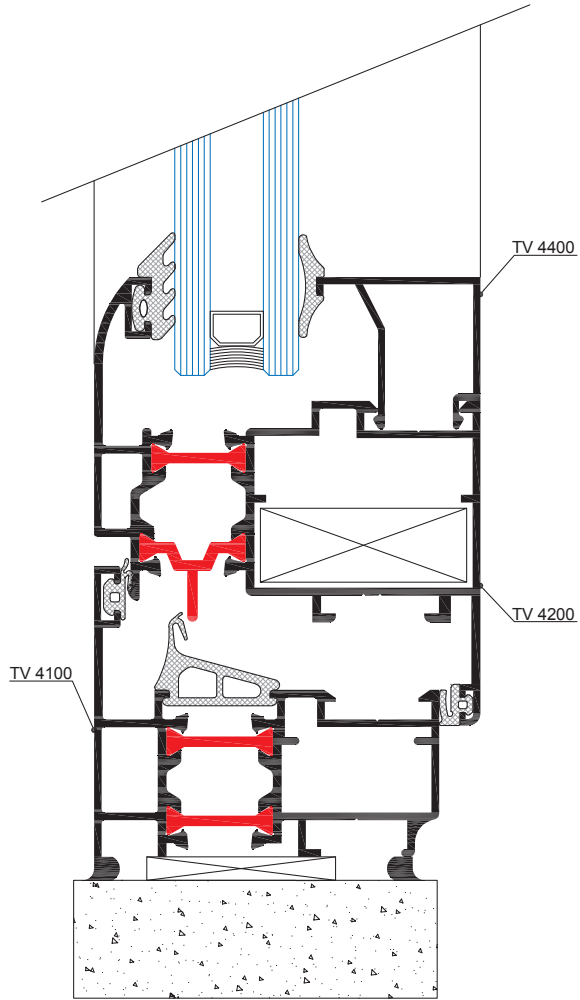
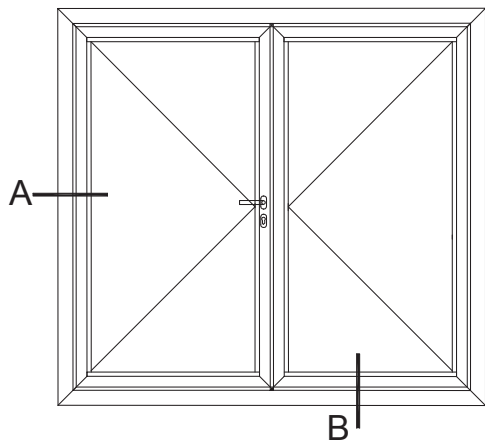

COUPE B

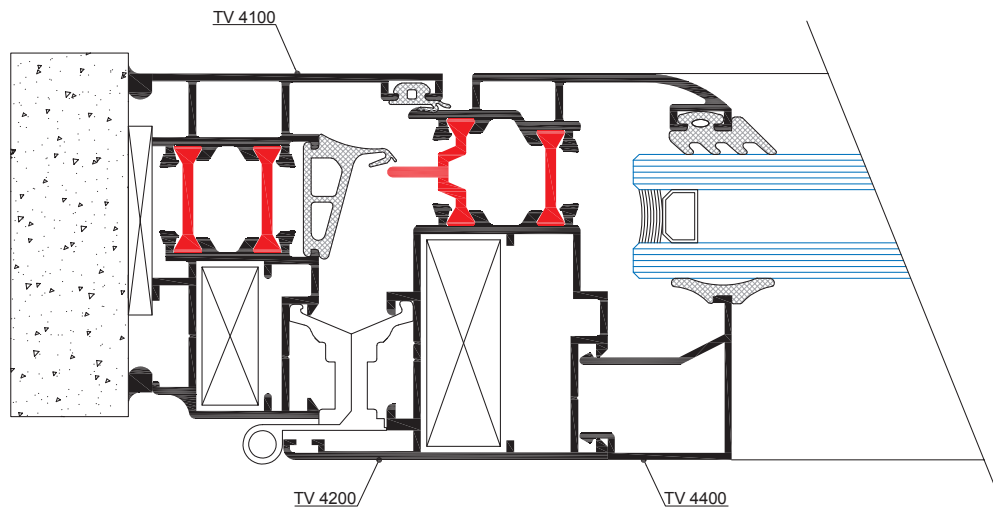

COUPE A

TV 400

Hinged System

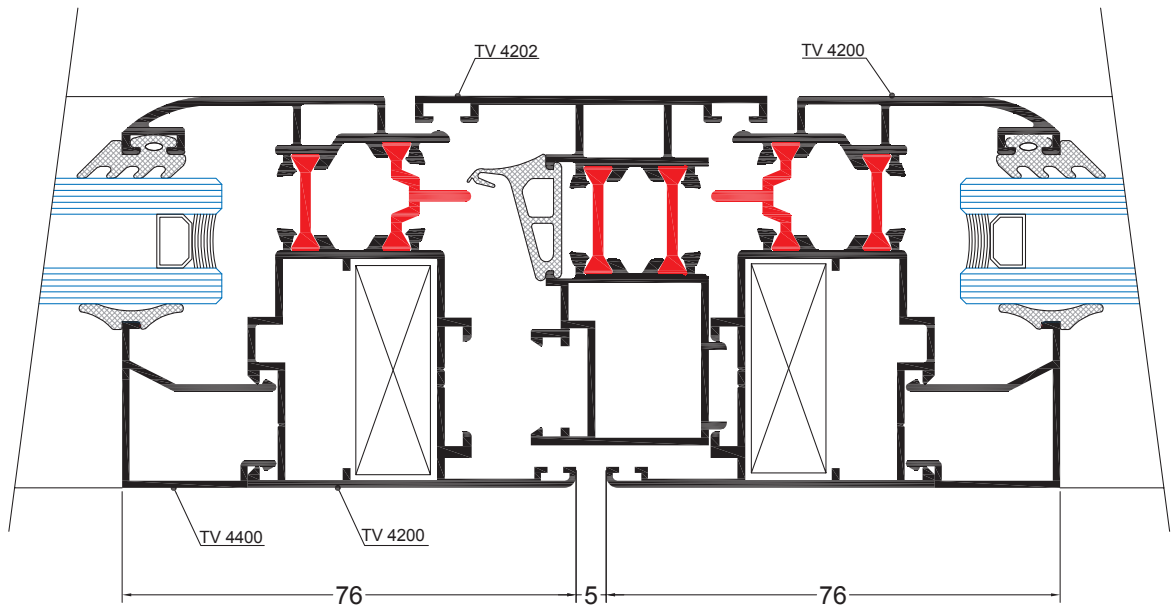
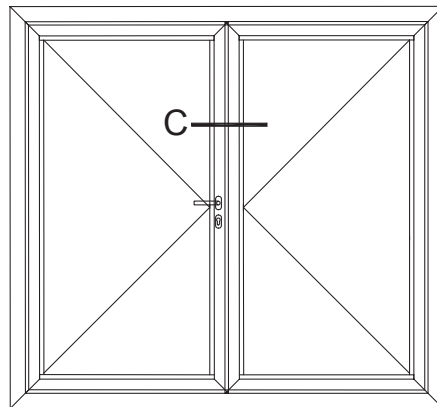

Hinged System

TV 400

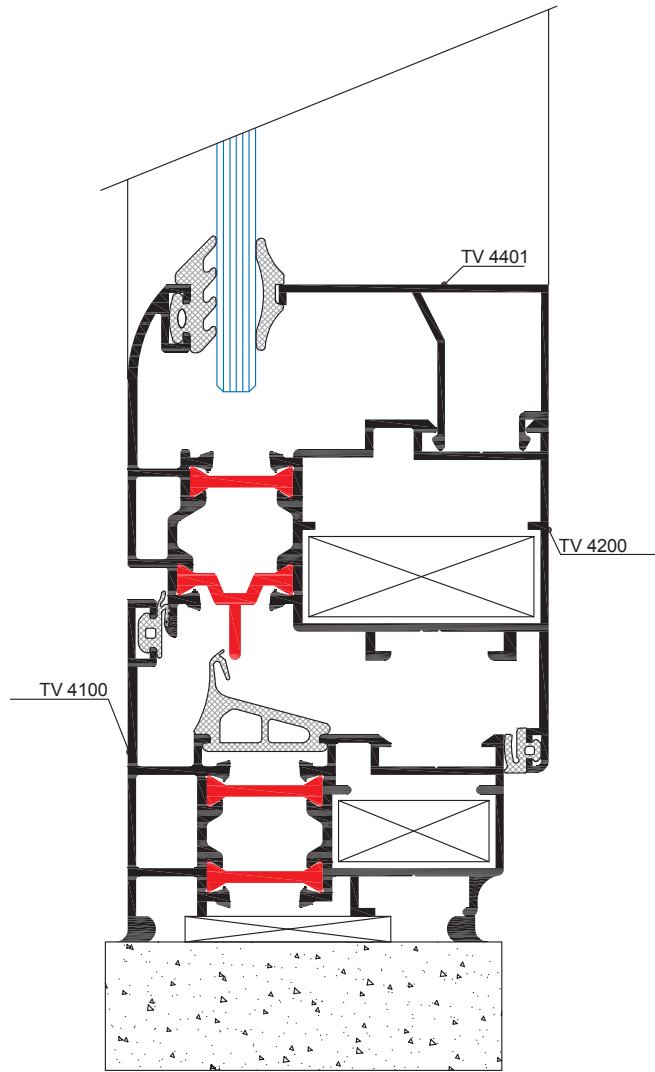
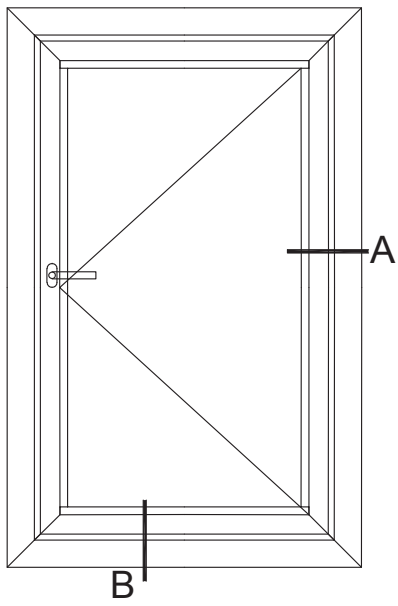

COUPE B

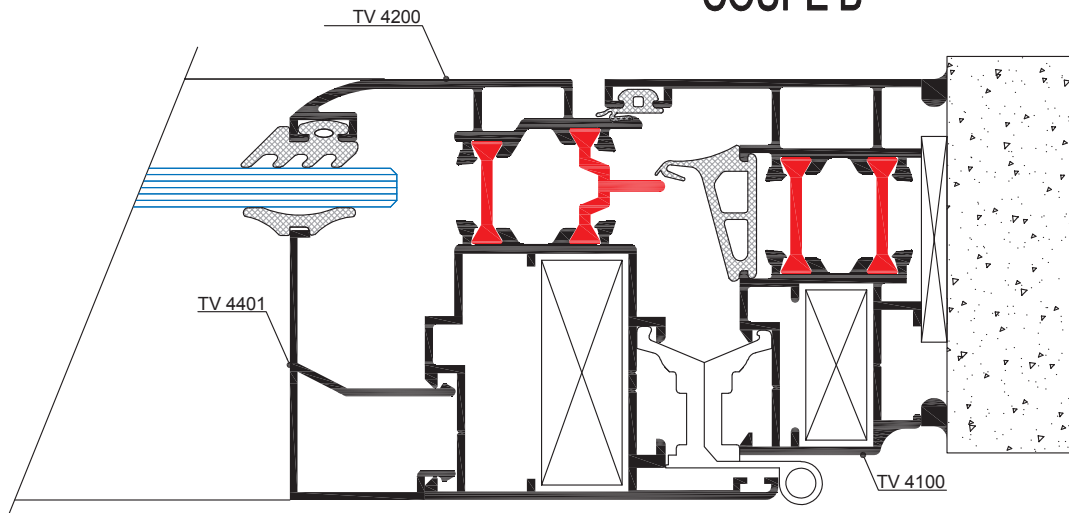

COUPE A

TV 400

Hinged System

TV 400

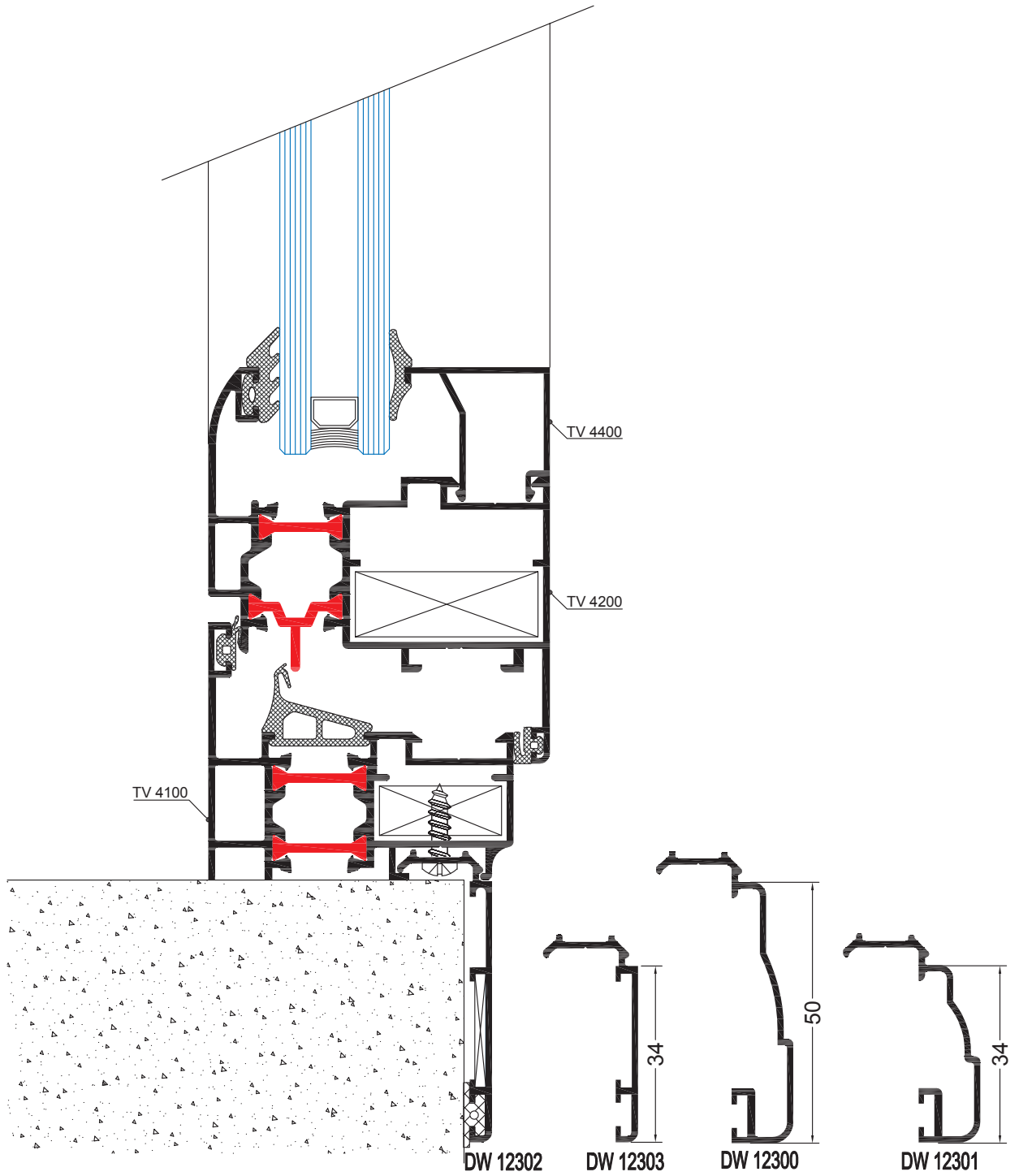

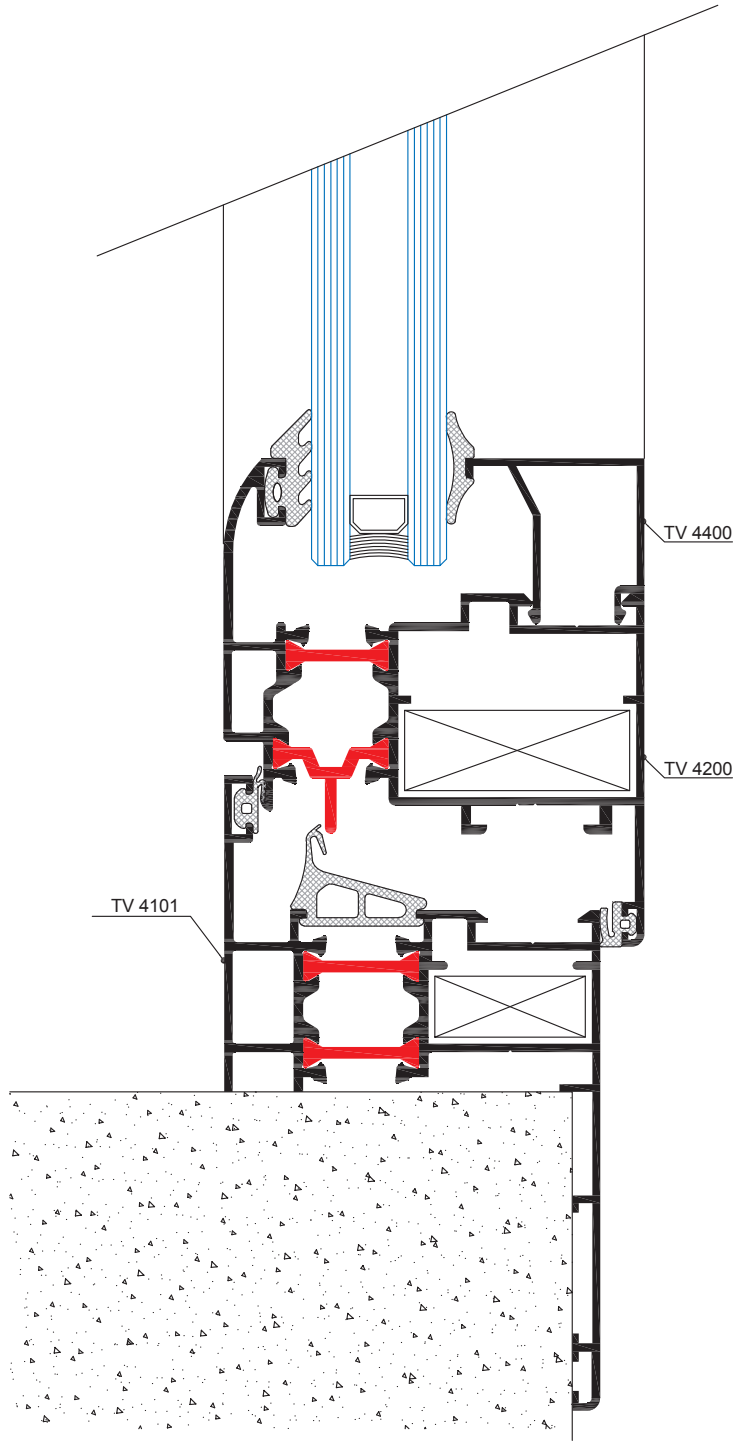

TV 400

Hinged System

TV 400

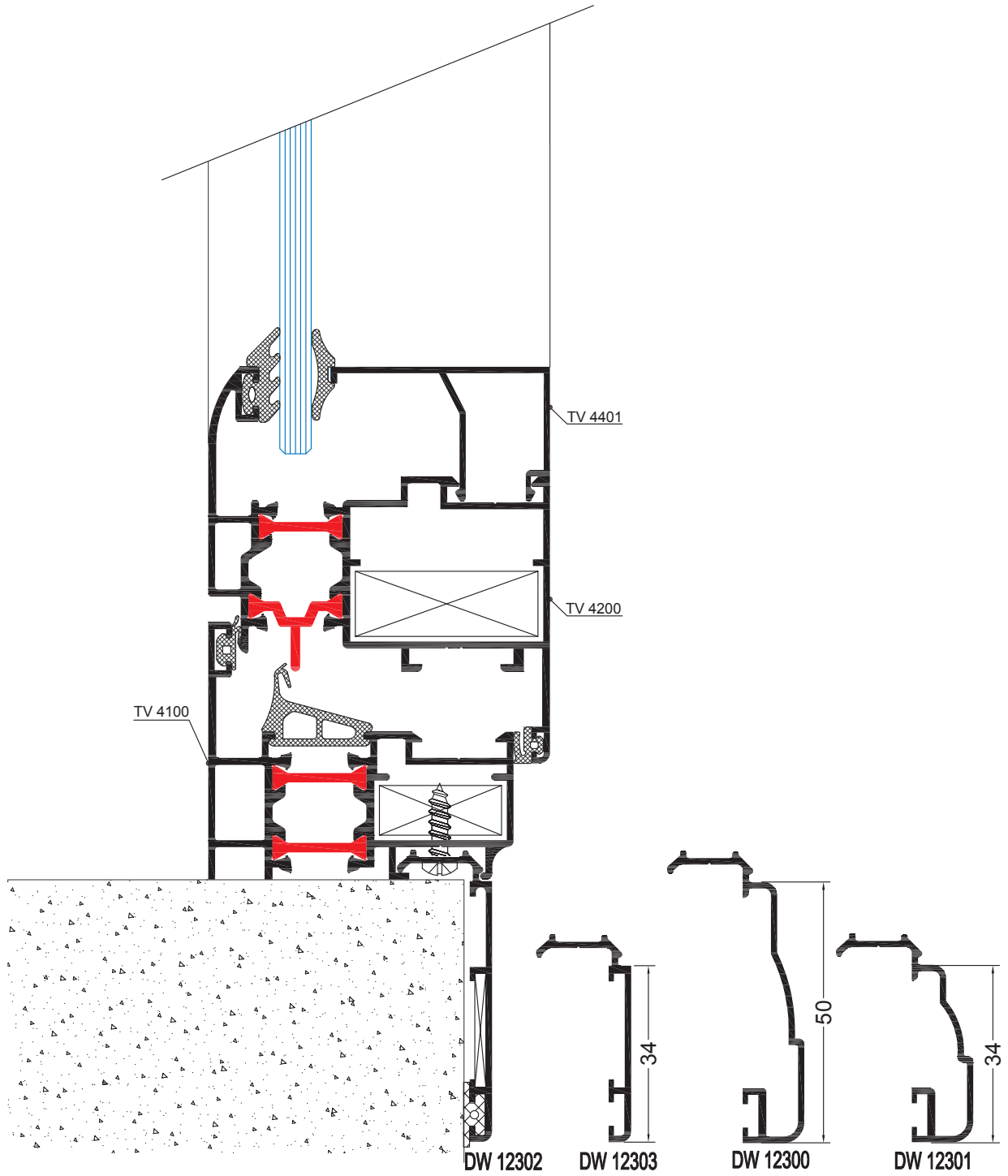

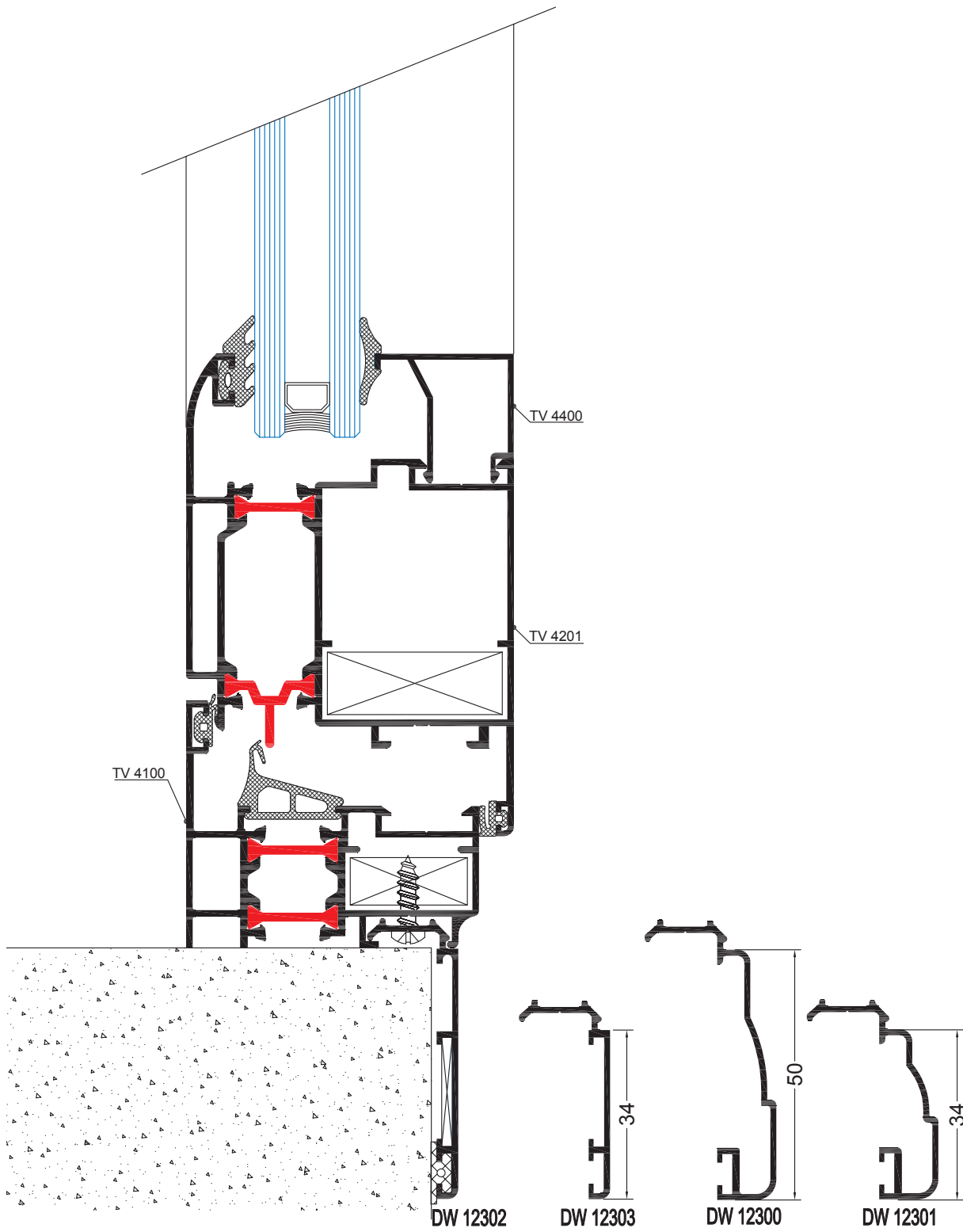

TV 400

Hinged System

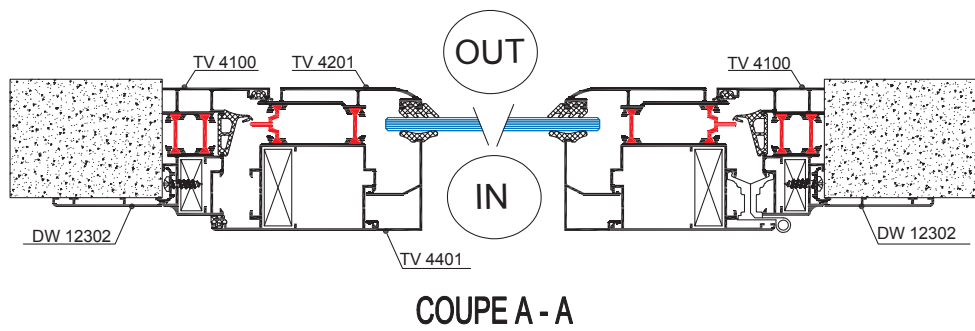
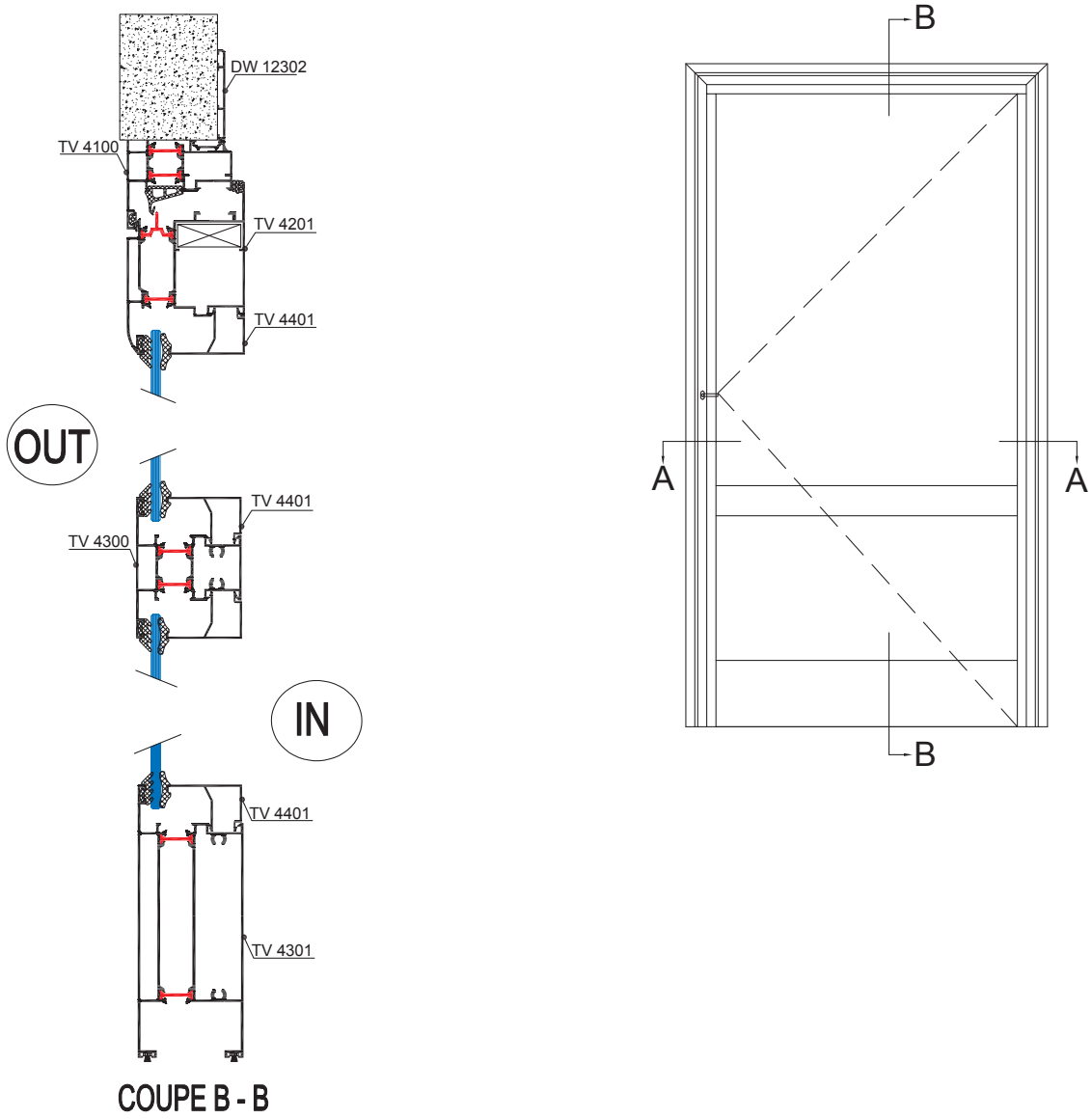

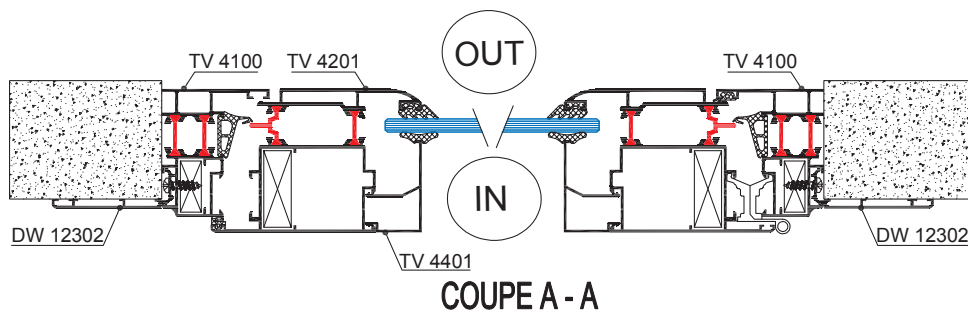
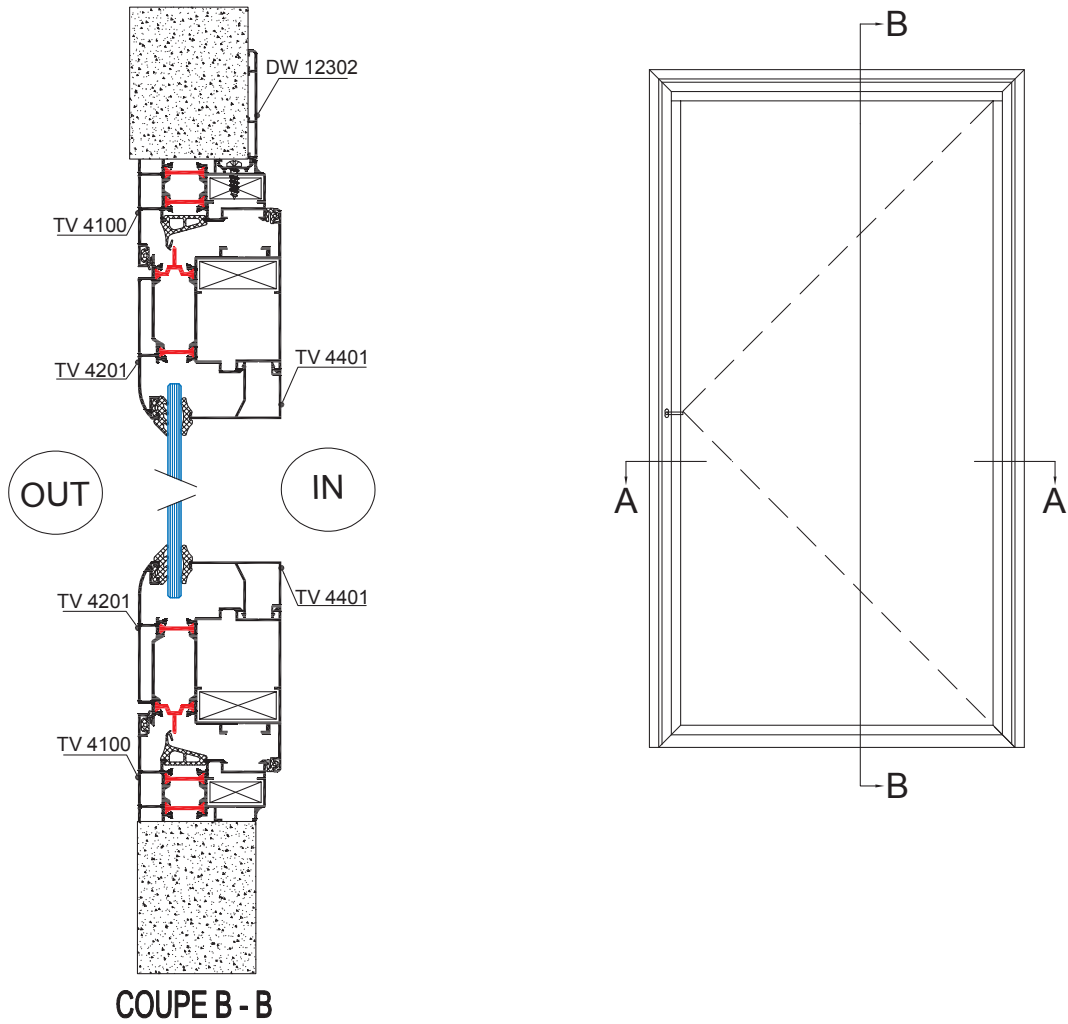

TV 400

Hinged System

